

What is different about this CST math study guide?

Dr. Clark applies her knowledge of math and test anxiety reduction to help students prepare for the CST.

Students project what their score might be by analyzing what they know. Math content is grouped by concepts in order to make the mathematics review easily manageable.

This further reduces the anxiety of students who struggle with math.

This book is ideal for students who experience high math anxiety as well as test anxiety. It is great for students who study independently as well as in a classroom tutoring environment.

Schools can use this book for short term intensive review courses, after school tutoring, or ongoing in class review.

The self-assessment that allows students to project how they might perform on the CST math test is a wonderfully helpful tool that parents can easily follow.

As a result, parents can better support their children to develop an effective and focused study plan.

Contents

Chapter 1	Page
<i>Teacher Introduction - How to use the program</i>	1
<i>Student Introduction</i>	2
<i>Exam overview</i>	2
<i>Standards Blueprint</i>	3
Chapter 2	
<i>How to use the Self-Analysis and Scoring Guide</i>	6
<i>Self Analysis</i>	7
<i>How the Grade 8 CST math test is scored</i>	10
Chapter 3 - Number Properties, Operations, and Linear Equations	
<i>Introduction</i>	11
<i>Important Vocabulary</i>	13
<i>Strand Trace - Mental Math</i>	14
<i>Vocabulary Activity</i>	16
<i>Short Answer</i>	18
<i>Multiple Choice</i>	20
<i>Mathematical Reasoning (MR)</i>	22
<i>Common Misconceptions</i>	24
Chapter 4 - Graphing and Systems of Linear Equations	
<i>Introduction</i>	26
<i>Important Vocabulary</i>	27
<i>Strand Trace - Mental Math</i>	28
<i>Vocabulary Activity</i>	31
<i>Short Answer</i>	33
<i>Multiple Choice</i>	35
<i>Mathematical Reasoning</i>	37
<i>Common Misconceptions</i>	38
Chapter 5 - Quadratics and Polynomials	
<i>Introduction</i>	42
<i>Important Vocabulary</i>	43
<i>Strand Trace - Mental Math</i>	44
<i>Vocabulary Activity</i>	46
<i>Short Answer</i>	48
<i>Multiple Choice</i>	51

Contents

<i>Mathematical Reasoning (MR)</i>	53
<i>Common Misconceptions</i>	55
Chapter 6 - Functions and Rational Expressions	
<i>Introduction</i>	55
<i>Important Vocabulary</i>	56
<i>Strand Trace - Mental Math</i>	57
<i>Vocabulary Activity</i>	59
<i>Short Answer</i>	61
<i>Multiple Choice</i>	63
<i>Mathematical Reasoning</i>	65
<i>Common Misconceptions</i>	66
Chapter 9	
<i>Practice Test A</i>	67
<i>Practice Test A Answer Key</i>	79
Chapter 10	
<i>Practice Test B</i>	80
<i>Practice Test B Answer Key</i>	93
Glossary	94
Important Websites	102

Quadratics and Polynomials

21 problems on the CST

Students understand the concept of quadratic functions and equations including the solution methods and graphs of quadratic functions. They perform operations around monomials and polynomials.

6, 5 items

No standard is tested with 5 or 6 questions in this reporting cluster

4 items

10.0* Students add, subtract, multiply, and divide monomials and polynomials. Students solve multistep problems, including word problems, by using these techniques.

3 items

14.0* Students solve a quadratic equation by factoring or completing the square.

20.0* Students use the quadratic formula to find the roots of a second-degree polynomial and to solve quadratic equations.

21.0* Students graph quadratic functions and know that their roots are the x-intercepts.

23.0* Students apply quadratic equations to physical problems, such as the motion of an object under the force of gravity.

2 items

11.0 Students apply basic factoring techniques to second- and simple third-degree polynomials. These techniques include finding a common factor for all terms in a polynomial, recognizing the difference of two squares, and recognizing perfect squares of binomials.

19.0* Students know the quadratic formula and are familiar with its proof by completing the square.

1 item

22.0 Students use the quadratic formula or factoring techniques or both to determine whether the graph of a quadratic function will intersect the x-axis in zero, one, or two points.

Quadratics and Polynomials

Important Vocabulary

Standard 10.0	Monomials and polynomials
Standard 14.0	Quadratic equation, factoring, and completing the square.
Standard 20.0	Quadratic formula, roots, and second-degree polynomial.
Standard 21.0	Graph, quadratic functions, and x-intercepts.
Standard 23.0	Application, quadratic equations, physical problems, motion of an object, and force of gravity.
Standard 11.0	Factoring techniques, third-degree polynomials, common factor, polynomial, difference of two squares, perfect squares, and binomials.
Standard 19.0	Quadratic formula, proof, and completing the square.
Standard 22.0	Quadratic formula, factoring techniques, graph of a quadratic function, intersect, x-axis.

Quadratics and Polynomials

Multiple Choice

6. Which of the following is the solution set of the quadratic equation $3x^2 + 7x + 3 = 0$?

a. $\left\{\frac{1}{3}, \frac{2}{3}\right\}$

b. $\left\{\frac{-7 + \sqrt{13}}{6}, \frac{-7 - \sqrt{13}}{6}\right\}$

c. No real root

d. $\left\{\frac{-7 + \sqrt{13}}{6}\right\}$

20.0 (3 Items)

9. A tennis ball is projected straight downward with initial velocity v of meter per second falls a distance $s = vt + 12t^2$ where t is time in seconds. If Serina is standing on a roof 100 feet above the ground and throws a marble straight down with initial velocity of 9.8 meter per second, in how many seconds will it touch the ground?

a. 2 seconds

b. 3 seconds

c. 4 seconds

d. 5 seconds

23.0 (3 Items)

7. Multiply the following binomials.
 $2x - 5$ and $3x + 6$

a. $6x - 1$

b. $6x^2 + 1$

c. $6x^2 - 3x - 30$

d. $5x - 3x$

10.0 (4 Items)

10. Which of the following polynomials will multiply to give this product?
 $3x(2x^2 - 4x + 3)$

a. $6x - 12x + 9$

b. $6x^3 - 12x^2 + 9x$

c. $6x^2 - 12x + 9x$

d. $6x^3 - 12x^2$

10.0 (4 Items)

8. Which of these binomials will give the following polynomial? $2x^2 + 7x + 3$

a. $(2x + 1)(2x + 3)$

b. $(2x + 1)(x - 3)$

c. $(2x - 1)(x - 3)$

d. $(2x + 1)(x + 3)$

11.0 (2 Items)

11. Factor $8x^3 + 6x^2 - 2x$.

a. $x(4x - 1)(x + 1)$

b. $2x(4x - 1)(x + 1)$

c. $x(8x + 4)$

d. $2x^2(4x - 1)$

11.0 (2 Items)

Quadratics and Polynomials

with Mathematical Reasoning (MR)

A square piece is cut off from each corner of a cardboard as shown in the diagram below.

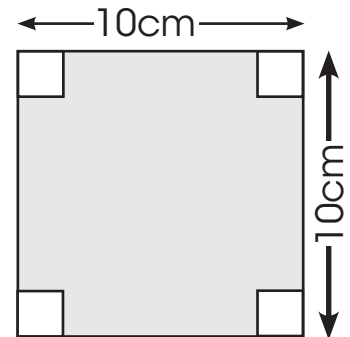

- If the cardboard is folded to form a box, write an expression to represent the volume of the box formed.

$$100x - 40x^2 + 4x^3$$

- After cutting off the four squares from the corners, what is the area of the remaining piece?

$$100 - 40x + 4x^2$$

- Graph the function of the area and find the roots of the graph.

$$f(\text{area}) = 25 - 10x + x^2$$

(The root is 5)



Practice Test A

51. Write an equation of a line that has a slope of $\frac{3}{2}$ passing through the point (0,1).

A. $y = 2x + 1$

B. $y = \frac{3}{2}x - 1$

C. $y = \frac{3}{2}x + 1$

D. $y = \frac{2}{3}x + 1$

Alg. 7.0

55. Which of the following inequalities is represented in this graph?

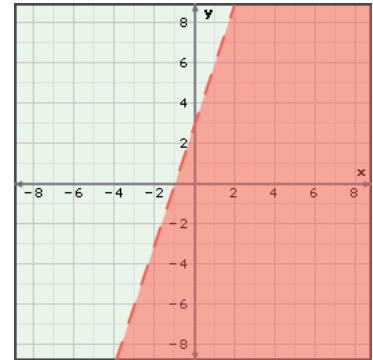

A. $y > 3x$

B. $y < 3x$

C. $y > 3x + 3$

D. $y < 3x + 3$

Alg. 6.0

52. Write the x-intercept of $\frac{2}{5}x + y = 4$

A. 5

B. 8

C. 10

D. 12

Alg. 6.0

56. What is the product of these polynomials $3x(2x^2 - 4x + 3)$

A. $6x - 12x + 9$

B. $6x^3 - 12x^2 + 9x$

C. $6x^2 - 12x + 9x$

D. $6x^3 - 12x^2$

Alg. 10.0

53. Multiply the following polynomial.
 $2x - 5$ and $3x + 6$

A. $6x - 1$

B. $6x^2 + 1$

C. $6x^2 - 3x - 30$

D. $6x - 3x$

Alg. 10.0

57. Which of these binomials will give the following polynomial? $2x^2 + 7x + 3$

A. $(2x + 1)(2x + 3)$

B. $(2x + 1)(x - 3)$

C. $(2x - 1)(x - 3)$

D. $(2x + 1)(x + 3)$

Alg. 11.0

54. Factor $8x^3 + 6x^2 - 2x$

A. $x(4x - 1)(x + 1)$

B. $2x(4x - 1)(x + 1)$

C. $x(8x + 4)$

D. $2x^2(4x - 1)$

Alg. 11.0

58. Which of the following is the solution set of the quadratic equation $3x^2 + 7x + 2 = 0$?

A. (3,-7)

B. (-7,3)

C. $(1, -\frac{1}{3})$

D. $(-2, -\frac{1}{3})$

Alg. 14.0